

# 10NMB A520

## High Output Midbass Neo Transducer

### Key Features

- 100,5 dB SPL 1W / 1m average sensitivity (AIC on)
- 65 mm (2,5 in) Interleaved Sandwich Voice coil (ISV)
- 300 Watt AES power handling
- Neodymium motor assembly
- AIC (Active Impedance Control) secondary voice coil for superior intelligibility, very low distortion and inductance linearization

Suitable for high quality two way compact systems



### General Description

The 10NMB A520 is the evolution of the 10NDA520. The transducer is a 10" mid-bass transducer created for compact reflex 2-way enclosures, and when compared to 10NDA520 shows 1 dB increased sensitivity over all operative frequency range, as well as 600 Watts program power handling. It can be used in mid-low sections on line-array systems and everywhere very high quality mid-bass frequency range reproduction is needed.

The 10NMB A520 incorporates Active Impedance Control technology (AIC), consisting of an additional coil fixed on the pole piece and connected in parallel to the moving coil.

The magnetic field generated by AIC coil has the following effects:

- 1) Impedance linearization
- 2) Acoustic and electric phase linearization
- 3) Significant increase of sensitivity and total SPL
- 4) Total harmonic distortion reduction
- 5) Constant power transfer

By not absorbing the moving coil's electromagnetic energy, the AIC offers substantial advantages to the sound quality.

The external neodymium magnet assembly assures high flux concentration, low power compression and excellent heat exchange. The curvilinear cone, specified with a high damping wood pulp has been designed to achieve the best possible linearity within its frequency range. The 65 mm (2,5 in) diameter aluminum voice coil is wound on a strong fibreglas former in order to improve force transmission and power handling.

A special coating applied to both the top and back plates makes the 10NMB A520 far more resistant to the corrosive effects of salts and oxidization.

022108N520 8 Ohm

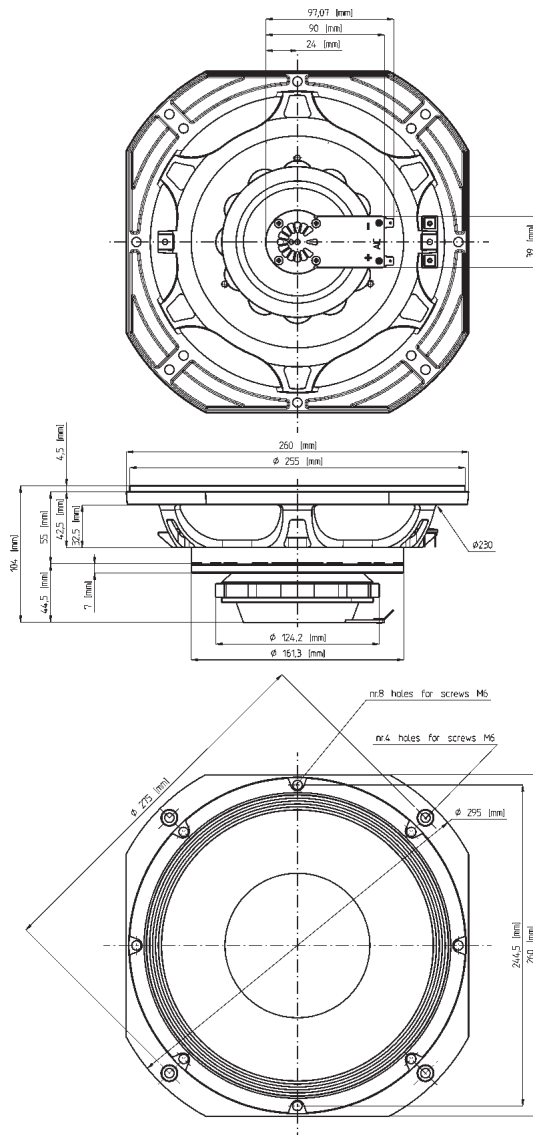

NEODYMIUM LF-MB-MF TRANSDUCERS

# 10NMBA520

High Output Midbass Neo Transducer

## GENERAL SPECIFICATIONS

NOMINAL DIAMETER	260mm (10 in)
RATED IMPEDANCE	8 Ohm
AES POWER	300W
PROGRAM POWER (1)	600W
PEAK POWER (2)	900W
SENSITIVITY (3)	100,5 dB
FREQUENCY RANGE (4)	60 - 7000 Hz
POWER COMPRESSION @-10DB (5)	0,7 dB
POWER COMPRESSION @-3DB	2,5 dB
POWER COMPRESSION @0DB	3,9 dB
MAX RECOMM. FREQUENCY	2000 Hz
RECOMM. ENCLOSURE VOLUME	10 ÷ 40 lt. (0,90 ÷ 1,41 cuft)
MINIMUM IMPEDANCE	6,3 Ohm at 25°C
MAX PEAK TO PEAK EXCURSION	24 mm (0,95 in)
VOICE COIL DIAMETER	65 mm (2,5 in)
VOICE COIL WINDING MATERIAL	aluminum
SUSPENSION	Double roll, polycotton
CONE	Curvilinear, paper

## THIELE SMALL PARAMETERS (6)

Fs	60 Hz
Re	5 Ohm
Sd	0,035 sq.mt. (54,25 sq.in.)
Qms	4,2
Qes	0,24
Qts	0,23
Vas	42 lt. (1,48 cu ft)
Mms	28 gr. (0,06 lb)
BL	14,6 Tm
Linear Mathematical Xmax (7)	±4 mm (±0,16 in)
Le (1kHz)	0,01 mH (AIC on) - 0,38 mH (AIC off)
Ref. Efficiency 1W@1m (half space)	97,8 dB

## MOUNTING INFORMATION

Overall diameter	260 mm (10,24 in)
N. of mounting holes and bolt	4 on diam. 275 mm (4 on 10,83 in) 8 on diam. 244,5 mm (4 on 9,63 in)
Mounting holes diameter	7,15 mm (0,28 in)
Front mount baffle cutout ø	232 mm (9,13 in)
Rear mount baffle cutout ø	232 mm (9,13 in)
Total depth	104 mm (4,09 in)
Flange and gasket thickness	14,5 mm (0,57 in)
Net weight	3 kg (6,67 lb)
Shipping weight	3,57 kg (7,88 lb)
CardBoard Packaging dimensions	275 x 275 x 164mm (10,83 x 10,83 x 6,46 in)

FREQUENCY RESPONSE CURVE OF 10NMBA520 (AIC ON) MADE ON 30 LIT. ENCLOSURE TUNED AT 55 HZ IN FREE FIELD (4PI) ENVIRONMENT. ENCLOSURE CLOSES THE REAR OF THE DRIVER. THE THIN LINE REPRESENTS 45 DEG. OFF AXIS FREQUENCY RESPONSE.

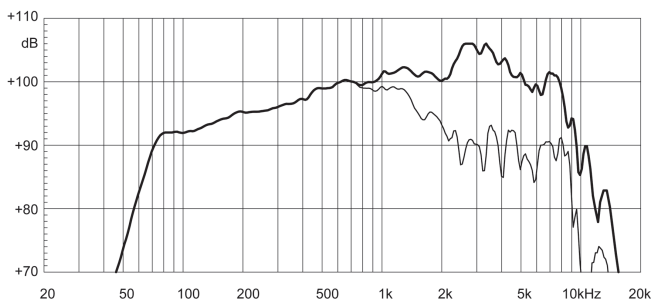

FREE AIR IMPEDANCE MAGNITUDE CURVE – AIC ON

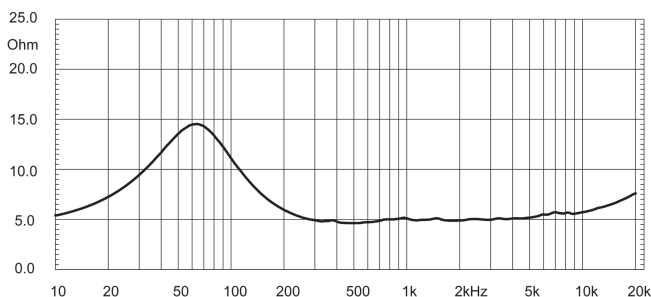

### NOTES

- (1) Program power rating is measured in 30 lit enclosure tuned at 55 Hz using a 100-3000Hz band limited pink noise test signal with 50% duty cycle, applied for 2 hours.
- (2) The peak power rating represents the maximum permitted instantaneous peak power level over a maximum period of 10ms which will be withstood by the loudspeaker without damage.
- (3) Sensitivity represents the averaged value of acoustic output as measured on the forward central axis of cone, at distance 1m from the baffle panel, when connected to 2,83V sine wave test signal swept between 500Hz and 2500Hz with the test specimen mounted in the same enclosure as given for (1) above.
- (4) Frequency range is given as the band of frequencies delineated by the lower and upper limits where the output level drops by 10 dB below the rated sensitivity in half space environment.
- (5) Power compression represents the loss of sensitivity for the specified power, measured from 100-1000 Hz, after a 5 min pink noise preconditioning test at the specified power.
- (6) Thiele - Small parameters are measured after the test specimen has been conditioned by 300 W AES power and represent the expected long term parameters after a short period of use.
- (7) Linear Math. Xmax is calculated as  $(Hvc-Hg)/2 + Hg/4$  where Hvc is the coil depth and Hg is the gap depth.

Eighteen Sound engages in research and product improvement. New materials and design refinements can be introduced into existing products without notice.